

Internet of Things (IoT)

Smart Monitoring System of Water Tank Based on Internet of Things

Abdillah Husaini ^{1*}, Yoshida Sary ²

¹ Department of Information Technology, Faculty of Computer Science and Information Technology, Universitas Muhammadiyah Sumatera Utara, Medan, 20238, North Sumatra, Indonesia

² Department of Information System, Faculty of Computer Science and Information Technology, Universitas Muhammadiyah Sumatera Utara, Medan, 20238, North Sumatra, Indonesia

ARTICLE INFORMATION

Received: July 27, 2024
Revised: August 18, 2024
Available Online: August 21, 2024

KEYWORDS

Ultrasonic Sensor
Flow Meter Sensor
Solenoid Valve
Blynk Application
Internet of things

CORRESPONDENCE (*)

Phone: +62 851-7308-9427
E-mail: abdillahhest3@gmail.com

A B S T R A C T

The first village located in Sei Meran Village, Pangkalan Susu Subdistrict, with a population of 640 people consisting of 325 men and 315 women. The village experienced clean water scarcity and received assistance in the form of a drilled well, water pump, and water tank from the Langkat Police Chief through the POLRI Cares for the Environment program. This program significantly improved villagers' access to clean water. However, the village administration and the village head found it challenging to monitor and calculate the fair distribution of clean water. This issue was addressed by implementing an Internet of Things (IoT)-based smart water tank system. This automated system incorporates various sensors, including an ultrasonic sensor and a relay module, to control the water pump and fill the water tank. Additionally, a 4x4 keypad allows villagers to enter an access code that activates the solenoid valve and water flow sensor to measure the distributed water volume. The system can be remotely monitored via the Blynk application using internet access. The ESP8266 microcontroller serves as the data center and control unit. The test results show that the ultrasonic sensor has an average accuracy of 98.7% in measuring distance, while the flow meter sensor has an average accuracy of 98.3% in measuring water flow volume. This system can accurately and efficiently monitor water levels and water withdrawal, automating the water resource management process in the tank.

INTRODUCTION

Water is the most important substance in human life. Water is needed by all living things on earth to survive. In everyday life, water is often used for drinking, bathing, washing, cooking and so on. The human body consists of 60% water, so water is needed to maintain normal body functions. However, in everyday life, there are still many activities that use water inefficiently, so that clean water is wasted.

Water tanks are an important infrastructure in meeting people's daily water needs. Water tanks function to store water from water sources, such as PAM, wells, or springs. The water stored in the water tank can then be used for household needs, such as bathing, washing, cooking, and drinking. This water tank is also widely used for office needs, such as for toilets, kitchens, and office equipment. Even water tanks are also widely needed for industrial needs such as for production processes, sanitation or cooling.

There is a hamlet that is experiencing difficulties in getting clean water, the hamlet is Sei Pandan Hamlet located in Sei Meran Village, Pangkalan Susu District. The hamlet is experiencing difficulties in getting clean water, so it received assistance in the form of a drilled well, a water pump machine and a water tank from the Langkat Regency Police Chief through the POLRI Cares for the Environment program. Until now, the drilled well infrastructure is still used by local residents to get a source of clean water. The drilled well infrastructure is guarded by the Head of Sei Pandan Hamlet.

Every community who wants to take clean water to the drilled well infrastructure must bring a place to store water such as a bucket, bucket and so on. With an affordable clean water capacity, Sei Meran Village will make regulations to limit the taking of clean water from the drilled well infrastructure in Sei Pandan Hamlet. The regulation is that every resident who comes to get clean water will get approximately 70-110 liters of clean water per day, adjusting the number of families in their respective homes. With this regulation, the village hopes that clean water can be distributed accurately and fairly. This makes it difficult for the Head of Sei Pandan Hamlet to calculate the amount of water that will be released from the water tank when residents come to get clean water. The Head of Sei Pandan Hamlet also has to check the stock of clean water in the water tank, turn the water pump machine on and off manually when the water in the water tank is low. This is because the water pump machine provided by the LANGKAT POLICE CHIEF through the POLRI Cares for the Environment program still uses a manual water pump machine. Inaccurate water level indicators in water tanks can cause water availability to become uncontrolled. This is because we cannot know for sure when the tank is full or empty. As a result, water can overflow and be wasted, or we need to turn the water pump on and off frequently, which can cause inconvenience (Gunawan et al., 2020).

The distance between Sei Meran Village and Sei Pandan Hamlet is quite far, approximately 12 kilometers with bad roads, making it difficult for the village to monitor the condition of the drilled well in implementing the regulations that have been made to run smoothly. There needs to be a remote monitoring system to monitor the extraction of clean water from the drilled well accurately.

Therefore, in this study, an intelligent monitoring system for water tanks based on the Internet of Things will be created. This system allows the water pump machine to turn on automatically when the water in the tank starts to decrease and the water pump machine can turn off automatically when the water tank is full. This system can also make it easier for the Head of Sei Pandan Hamlet to distribute the amount of clean water to the Sei Pandan Hamlet community accurately and fairly, according to the rules made by Sei Meran Village. This system is also equipped with a water usage monitoring display that can be monitored directly by the Head of Sei Meran Village remotely. This makes it easier for the Village Head to monitor the extraction of clean water in the hamlet so that it can run smoothly according to the regulations made. With the existence of an intelligent monitoring system for water tanks based on the Internet of Things, the infrastructure of the drilled well can experience significant changes in the management and utilization of clean water resources.

METHOD

Complete Tool Set

In designing a smart monitoring tool for IoT-based water tanks, there are a series of designs that will be carried out, namely as follows:

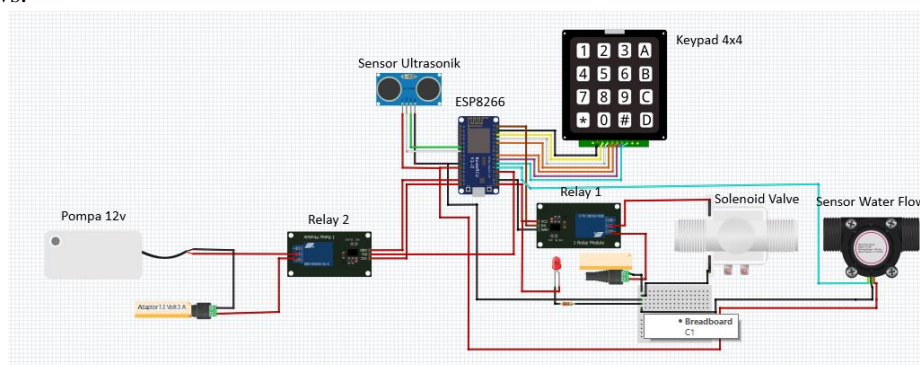

Figure 1. Hardware Series

Monitoring Application

In designing an IoT-based smart water tank monitoring system, there is a monitoring display that will be created using the Blynk application, namely as follows:

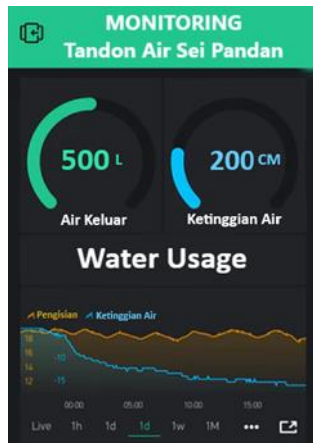

Figure 2. Monitoring Application

RESULTS AND DISCUSSION

Hardware Design Results

In designing a water level monitoring and control system in a tank, the results of the hardware design used consist of various electronic and mechanical components. In the NodeMCU microcontroller, a feature is already available to connect to wifi, so that it can be connected to the Internet. In addition, there is also a relay used to control the solenoid valve, so that it can be opened and closed. Namely the HC-SR04 Water Level sensor, 1 Channel Relay, AC / DC pump, Electric solenoid valve, water flow meter, 4x4 keypad, 12V 10 A adapter, Charger adapter, USB Female, water tank or mini water gallon and jumper cable. The results of the display of the designed tool can be seen in Figure 4.19 below:

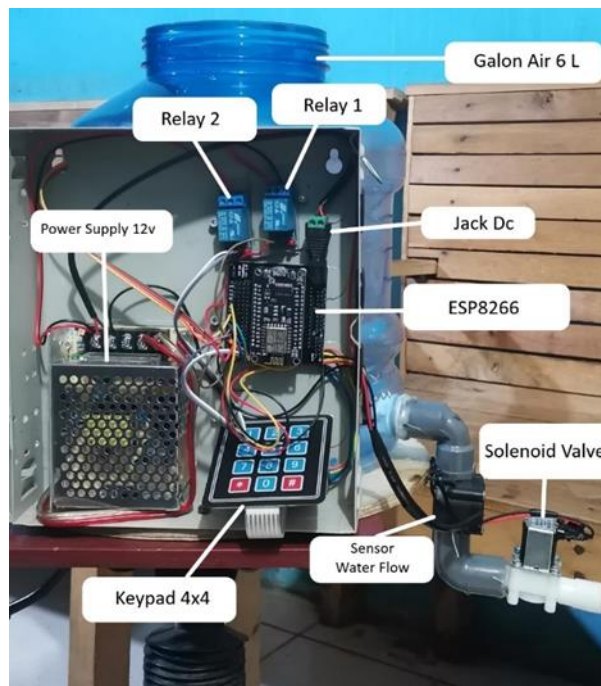

Figure 3. Tool Design Result View

Power Supply Testing

Testing on the power supply circuit serves to measure the output voltage value of the adapter used. This is done in order to find out the amount of voltage issued by the adapter to ensure that the value is in accordance with the needs of the electronic components used in the system.



Figure 4. Power Supply Testing Power Supply

In figure 4 is a series of power supply tests from the voltage source used, namely using a 12volt 10 A power supply to drive the water pump, and a 5volt adapter to provide voltage supply for electronic components such as solenoids, pumps and relays. The results of this measurement show that the input value coming out of the power supply circuit is 12.47 volts.

HC-SR04 Water Level Sensor Testing

The HC-SR04 ultrasonic sensor output test was conducted to test the accuracy of the distance readings produced by the sensor. In this test, the ultrasonic sensor is directed at the water surface at different distances, and the distance reading data produced by the sensor will be compared with manual measurements using a ruler or other measuring instrument. The purpose of this test is to ensure that the ultrasonic sensor can provide accurate distance readings, so that it can be used to monitor the water level in the tank accurately. This test was conducted 2 times, namely testing water measurements with a distance of 5 cm between the surface of the ultrasonic sensor and the water and testing water measurements with a distance of 15 cm between the surface of the ultrasonic sensor and the water, as can be seen in Figure 4.3 below:

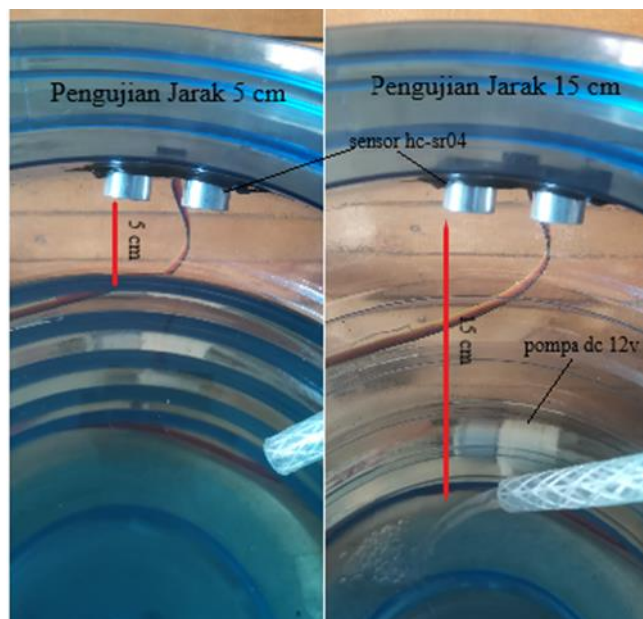

Figure 5. Water Level Sensor Distance Testing

It can be seen in figure 5 above, when the ultrasonic sensor reads the distance between the water and the ultrasonic sensor surface of 5 cm, the 12v dc pump is off (does not fill the water in the water tank) and when the ultrasonic sensor reads the distance between the water and the ultrasonic sensor surface of 15 cm, the 12v dc pump is on (fills the water in the water tank). Furthermore, there is a voltage output measured on the Water Level sensor, namely:

Table 1. Water Level Output Voltage Measurement

Sensor Water Level	Output Voltage
Measurement Point	(Volt) DC
Pin VCC	3.7 Volt

Testing of Flow Meter Sensor and Solenoid Valve

Flowmeter testing is carried out to test the accuracy of the water flow rate reading produced by the flowmeter. In this test, a certain volume of water is flowed through the solenoid valve to the flowmeter, and the water volume reading data produced by the flowmeter will be compared with the actual water volume. The purpose of this test is to ensure that the flowmeter can provide accurate water flow rate readings, so that the amount of water taken by the user can be monitored properly.



Figure 6. Flow Meter Measurement on Water Pipes

In Figure 6 above, the researcher measured the output or output of the water flow in the water tank used.

Table 2. Water Flow Meter Sensor Output Voltage

Water Flow Meter	Output Voltage
Digital Pin	Pin D7
VCC	3.3 Volt
Measurable voltage	4.12 volt

4x4 Keypad Sensor Testing

Keypad testing is done to ensure that the keypad can work properly in receiving input from users or villagers. In this test, each button on the keypad is pressed one by one, and the microcontroller will read and record the input received from the keypad. The results of this input reading are then compared with the input that should be received. The purpose of this test is to ensure that the keypad can receive input from users accurately, so that users or beneficiaries of water assistance in the village can enter the code correctly to take water from the reservoir.



Figure 7. 4x4 Keypad Sensor Testing

Water Level Sensor Accuracy Testing Data Results

The accuracy test of the HC-SR04 ultrasonic sensor was carried out to determine how accurate the sensor is in measuring the distance between the sensor surface and the water surface in the tank. In the program configuration, the HC-SR04 water level sensor is used as a water level monitor in the tank, the sensor is programmed with a certain height distance to give commands to the relay. When the water level is above 15 cm from the ultrasonic sensor distance, the pump relay will be active to fill the water tank, if the water distance has reached 5 cm from the ultrasonic sensor surface, the relay will turn off again. The following is a serial monitor program display that can be seen:

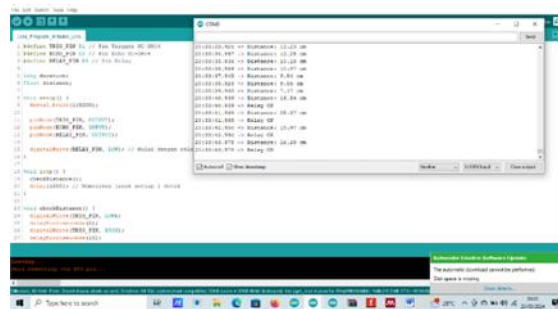

Figure 8. Arduino IDE Program View Water Level Initiation

In this test, the ultrasonic sensor is directed towards the water surface at different distances, and the distance reading data generated by the sensor is compared with manual measurements using a ruler or other measuring instrument.

The table of measurement data measured by the HC-SR04 water level sensor during implementation for 1 (one) day in the field can be seen in the table below:

Table 3. Periodic Ultrasonic Sensor Testing

No	Sensor Measured Distance (cm)	Time	Pump Status	Percentage of accuracy of reading reliability (%)
1	5 cm	08.00 wib	Off	100%
2	7.2 cm	10.00 wib	Off	100%
3	10.7 cm	12.00 wib	Off	100%
4	14.4 cm	13.00 wib	Off	100%
5	17.5 cm	14.20 wib	On	100%
6	14.0 cm	15.30 wib	Off	100%
7	15.4 cm	17.00 wib	On	100%
8	17.9 cm	17.30 wib	On	100%
9	19.6 cm	18.00 wib	On	100%
10	5 cm	21.00 wib	Off	100%

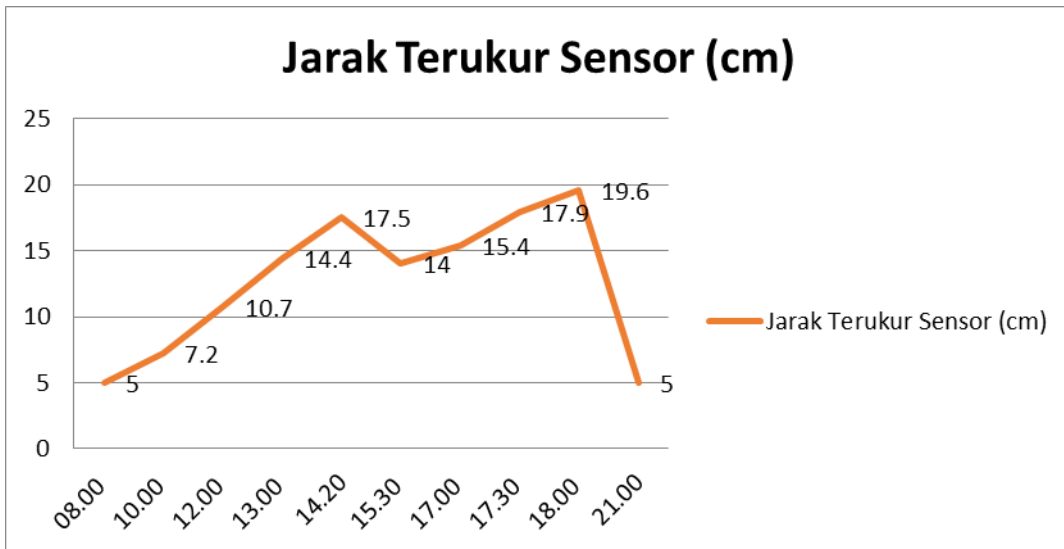

Figure 9. Sensor Measured Distance Measurement Graph

Based on the data in the table, it can be seen that at 08.00 WIB, the measured distance by the ultrasonic sensor was 5 cm, which indicates that the tank is full, so the pump is off. As time goes by, the measured distance increases, which indicates that the water level in the tank is decreasing. At 14.20 WIB, the measured distance reaches 17.5 cm, which indicates that the tank is quite empty, so the pump is on to refill the tank. The pump continues to run until 21.00 WIB, where the measured distance returns to 5 cm, which indicates that the tank is full, so the pump is off again. During testing, the ultrasonic sensor provides accurate distance readings with an accuracy percentage of 100%. This shows that the ultrasonic sensor can work well in monitoring the water level in the tank and controlling the pump to fill the tank automatically.

Flow Meter Sensor Test Data Results

Flowmeter sensor testing is carried out to determine how accurate the sensor is in measuring the rate of water flow coming out of the tank when water is taken by the community. In the tests that have been carried out, data from the water flow meter sensor is read through the blynk application in real-time. The display of the data that is read can be seen in the image below:



Figure 10. Water Flow Meter Reading Display Results

The next step in this test, a certain amount of water with a certain volume is flowed through the flow meter sensor, and the volume reading data generated by the sensor via the blynk application display is then compared with the actual volume of water measured manually using a measuring cup or other volume measuring tool.

From this data, it can be concluded that the flowmeter sensor can work well in measuring the water flow rate and volume of water taken by the community from the reservoir. This information is important for monitoring water use by the community and managing the availability of water in the reservoir better.

CONCLUSION

The conclusions of the research that has been conducted are as follows: The water level monitoring and control system in the reservoir has been successfully designed and implemented using the HC-SR04 ultrasonic sensor to measure the water level in the reservoir, the flowmeter sensor to measure the flow rate of water taken by the community, and the relay and solenoid valve to control the water pump and water intake tap, the HC-SR04 ultrasonic sensor has high accuracy in measuring the distance between the sensor surface and the water surface in the reservoir, with an average accuracy of around 98.7%. This allows the system to monitor the water level in the reservoir accurately, the flowmeter sensor also shows good accuracy in measuring the water flow rate and volume of water taken by the community, with an average accuracy of around 98.3%. This information is important for monitoring water usage by the community and better managing the availability of water in the reservoir, the control system using the relay and solenoid valve can work well in controlling the water pump and water intake tap automatically based on ultrasonic sensor readings and user input via the 4x4 keypad, with this system, the water level in the tank can be monitored in real-time, and water filling and withdrawal can be regulated automatically, thereby increasing the efficiency of water resource management.

REFERENCES

E-book

- [1] Muharman Lubis Ilham Firman Ashari, Debby Erce Sondakh, Rahmawati Rolly Junius Lontaan, Mustarum Musaruddin Indah Purnama Sari, Muh. Nadzirin Anshari Nur, Hanalde Andre Muh. Rais, Janner Simarmata. *Internet of Things (IoT) Dan Multimedia : Integrasi dan Aplikasi*, 2024. Yayasan Kita Menulis, 182
- [2] Mahdianta Pandia, Indah Purnama Sari, Alexander Wirapraja Fergie Joanda Kaunang, Syarifah Fitrah Ramadhani Stenly Richard Pungus, Sudirman, Suardinata Jimmy Herawan Moedjahedy, Elly Warni, Debby Erce Sondakh. *Pengantar Bahasa Pemrograman Python*, 2024. Yayasan Kita Menulis, 180
- [3] Indah Purnama Sari. *Buku Ajar Algoritma Dan Pemrograman*, 2023. UMSU Press
- [4] Indah Purnama Sari. *Buku Ajar Pemrograman Internet Dasar*, 2022. UMSU Press.
- [5] Surya Wisada Dachi & Indah Purnama Sari. *Aplikasi Komputer*, 2024. UMSU Press
- [6] Indah Purnama Sari. *Buku Ajar Rekayasa Perangkat Lunak*, 2021. UMSU Press

Journal Article from the Internet

- [7] Fahlevi, M.R., Gunawan, H., 2021. Perancangan Sistem Pendeteksi Banjir Berbasis Internet of Things. *It (Informatic Tech. J.* 8, 23. <https://doi.org/10.22303/it.8.1.2020.23-29>
- [8] Gede, I., Putrawan, H., Rahardjo, P., Gusti, I., Putu, A., Agung, R., 2019. Sistem Monitoring Tingkat Kekeuhan Air dan Pemberi Pakan Otomatis pada Kolam Budidaya Ikan Koi Berbasis NodeMCU. *Maj. Ilm. Teknol. Elektro* 19, 1–10. <https://doi.org/10.24843/MITE.2020.V19I01.P01>
- [9] Gunawan, I., Akbar, T., Giyandhi Ilham, M., 2020. Prototipe Penerapan Internet Of Things (Iot) Pada Monitoring Level Air Tandon Menggunakan Nodemcu Esp8266 Dan Blynk. *Infotek J. Inform. dan Teknol.* 3, 1–7. <https://doi.org/10.29408/jit.v3i1.1789>
- [10] Hanif, A., 2022. Rancangan Sistem Kontrol Dan Monitoring Instalasi Listrik Berbasis Internet of Things.
- [11] Junaldi, Ritmi, T., 2020. Perancang Alat Sistem Monitoring Volume Air Pada Tangki Air Berbasis Telegram Dengan Mikrokontroler NodeMCU. *J. Ilm. Poli Rekayasa* 16, 27. <https://doi.org/10.30630/jipr.16.1.190>
- [12] Rahman, A., 2018. Penyiraman Tanaman Secara Otomatis Menggunakan Propeler berbasis IoT. *ITEJ (Information Technol. Eng. Journals)* 3, 20–27. <https://doi.org/10.24235/ITEJ.V3I2.29>
- [13] Rindra, A.K., Widodo, A., 2021. Sistem Monitoring Level Ketinggian Air Pada Tandon Rumah Tangga Berbasis Iot (Internet Of Things). *J. Tek. Elektro* 11, 17–22. <https://doi.org/10.26740/jte.v11n1.p17-22>
- [14] Sugiarto, R., Kurniawan, M.I., 2020. Monitoring air dan ketinggian air pada tandon air berbasis web 01, 1–2.
- [15] Syafei, D.T., Watiasih, R., 2022. ID : 11 Aplikasi IoT Pada Sistem Kontrol dan Monitoring Tanaman Hidroponik *Application of IoT in Hydroponic Plant Control and Monitoring Systems* 73–86.

- [16] Sari, I.P., Basri, M., Ramadhani, F., & Manurung, A.A. (2023). Penerapan Palang Pintu Otomatis Jarak Jauh Berbasis RFID di Perumahan. *Blend Sains Jurnal Teknik 2* (1), 16-25
- [17] Sari, I.P., Al-Khowarizmi, A., Apdilah, D., Manurung, A.A., & Basri, M. (2023). Perancangan Sistem Pengaturan Suhu Ruangan Otomatis Berbasis Hardware Mikrokontroler Berbasis AVR. *sudo Jurnal Teknik Informatika 2* (3), 131-142
- [18] Sari, I.P., Al-Khowarizmi, A., Hariani, P.P., Perdana, A & Manurung, A.A. (2023). Implementation And Design of Security System On Motorcycle Vehicles Using Raspberry Pi3-Based GPS Tracker And Facedetection. *Sinkron: jurnal dan penelitian teknik informatika 7* (3), 2003-2007
- [19] Sari, I.P., Batubara, I.H., & Basri, M. (2022). Implementasi Internet of Things Berbasis Website dalam Pemesanan Jasa Rumah Service Teknisi Komputer dan Jaringan Komputer. *Blend Sains Jurnal Teknik 1* (2), 157-163
- [20] Sari, I.P., Novita, A., Al-Khowarizmi, A., Ramadhani, F., & Satria, A. (2024). Pemanfaatan Internet of Things (IoT) pada Bidang Pertanian Menggunakan Arduino UnoR3. *Blend Sains Jurnal Teknik 2* (4), 337-343
- [21] Husaini, A., & Sari, I.P. (2023). Konfigurasi dan Implementasi RB750Gr3 sebagai RT-RW Net pada Dusun V Suka Damai Desa Sei Meran. *sudo Jurnal Teknik Informatika 2* (4), 151-158